

## Low Profile Boom (LPB)

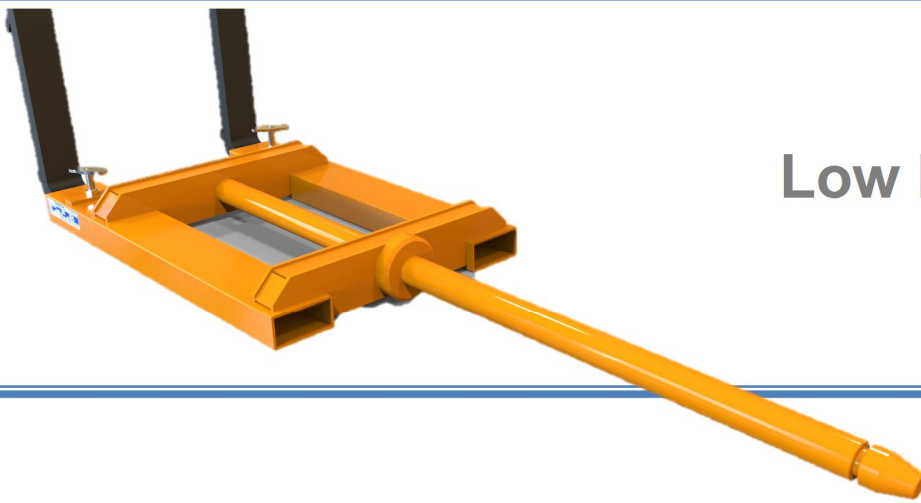

Low Profile Booms (LPB) offer fast and safe transport of rolled/coiled products. To use the boom, raise the carriage until the boom is at the height corresponding to that of the roll/coil. Drive slowly forwards ensuring that the boom is located as far into the core of the load as possible. Lifting can then be effected.

In the case of cylindrical loads, always ensure that the boom enters the load to a depth of at least two thirds, measured from the front face of the pole retaining the structure. To deposit the load, lower it onto the appropriate surface, ensuring that it is in a stable position. Lower the boom until it is free of the load and reverse the truck slowly.

The Low Profile Boom (LPB) is designed for low capacity applications, this boom as with the Clearview boom (FMB) allows fast changeover from pallet to roll handling, but with the added advantage of a low profile.

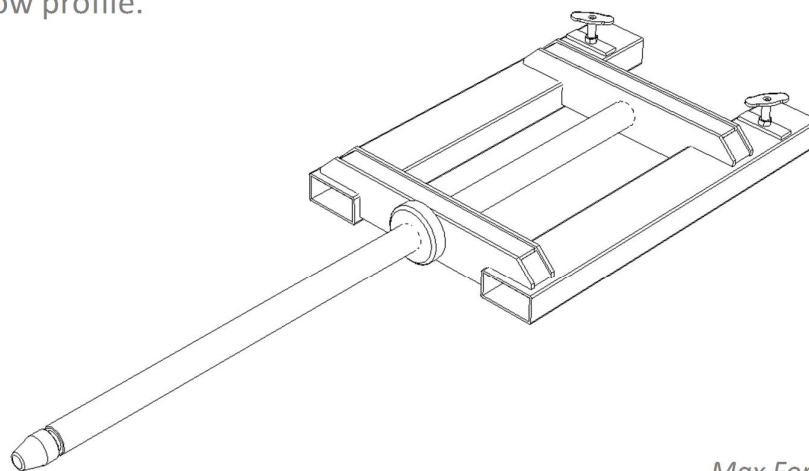

*Max Fork Size 140 x 50mm*

Model Ref.	Capacity @ 500mm	Pole Dia	L.L.C.	Max Fork Spread
LPB 50	1000kgs	50mm	1140mm	738mm
LPB 65	1250kgs	65mm	1140mm	738mm
LPB 70	1500kgs	70mm	1140mm	738mm
LPB 75	2000kgs	75mm	1140mm	738mm
LPB 90	3000kgs	90mm	1140mm	738mm