



WARRIOR 153

Electric Pallet Truck 1.5T



- ▶ Smart lithium battery with built in charger and 3 pin plug
- ▶ Newly designed handle head
- ▶ Passed market tests for safety and reliability

WARRIOR

WARRIOR 153

Electric Pallet Truck 1.5T

FEATURES

▶ SMART LITHIUM BATTERY

EPL153 uses lithium batteries and built-in chargers, so it can be used even when charged. It saves worries about the endurance and there is no need of special charging area.



▶ NEWLY DESIGNED HANDLE HEAD

EPL153 is lifted by electricity and lowered manually, there is no need to worry about damaging goods by uncontrollable lowering.



▶ PASS MARKET TESTS OF SAFETY AND RELIABILITY

EPL153 has 10-year market-tested components.



CE



WARRIOR

WARRIOR 153

Electric Pallet Truck 1.5T

DISTINGUISHING MARK				
1.1	Manufacturer			Warrior
1.2	Model designation			EPL153
1.3	Driver unit			Battery
1.4	Operator type			Pedestrian
1.5	Rated capacity	Q	Kg	1500
1.6	Load center distance	c	mm	600
1.8	Load distance	x	mm	950 (880)
1.9	Wheelbase	y	mm	1190 (1120)
WEIGHT				
2.1	Service weight (include battery)		Kg	115
2.2	Axle loading with load,driving side/loading side		Kg	540/1070
2.3	Axle loading without load,driving side/loading side		Kg	100/15
TYPES, CHASSIS				
3.1	Tyre type driving wheels/loading wheels			PU
3.2	Tyre size, driving wheels (diameter × width)		mm	Ø210 x 70
3.3	Tyre size, loading wheels (diameter × width)		mm	Ø210 x 70
3.4	Tyre size, caster wheels (diameter × width)		mm	Ø80 x 60 (Ø74 x 88)
3.5	Wheels, number driving, caster/loading (x=drive wheels)		mm	1 x /4 (1 x /2)
3.6	Track width, front, driving side	b10	mm	
3.7	Track width, front, loading side	b11	mm	
DIMENSIONS				
4.4	Lift height	h3	mm	115
4.9	Height drawbar in driving position min./max.	h14	mm	750/1190
4.15	Lowered height	h13	mm	80
4.19	Overall length	l1	mm	1550
4.20	Length to face of forks	l2	mm	800 x 520
4.21	Overall width	b1	mm	560 (685)
4.35	Fork dimensions	sxexl	mm	50 x 150 x 1150
4.36	Distance between fork-arms	b5	mm	560 (685)
4.37	Ground clearance, center of wheelbase	m2	mm	30
4.38	Aisle width for pallets 1000 × 1200 crossways	Ast	mm	1650
4.39	Aisle width for pallets 800 × 1200 lengthways	Ast	mm	1850
4.35	Turning radius	Wa	mm	1390
PERFORMANCE DATA				
5.1	Travel speed, laden/unladen	km/h	km/h	4/4.5
5.2	Lifting speed, laden/unladen		m/s	0.017/0.024
5.3	Lowering speed, laden/unladen		m/s	0.09/0.06
5.8	Max. gradeability, laden/unladen		%	6\16
5.10	Service brake type			electric
ELECTRIC-ENGINE				
6.1	Drive motor rating S2 60 min		kW	0.75
6.2	Lift motor rating at S3 15%		kW	0.5
6.3	The maximum allowed size battery		mm	230 x 260 x 85
6.4	Battery voltage/nominal capacity K5		V/Ah	24/20
6.5	Battery weight		Kg	5
ADDITIONAL DATA				
8.1	Type of drive control			DC
10.5	Steering type			mechanical
10.7	Sound pressure level at the driver's ear		dB (A)	< 74

WARRIOR 153

Electric Pallet Truck 1.5T

SPECIFICATIONS

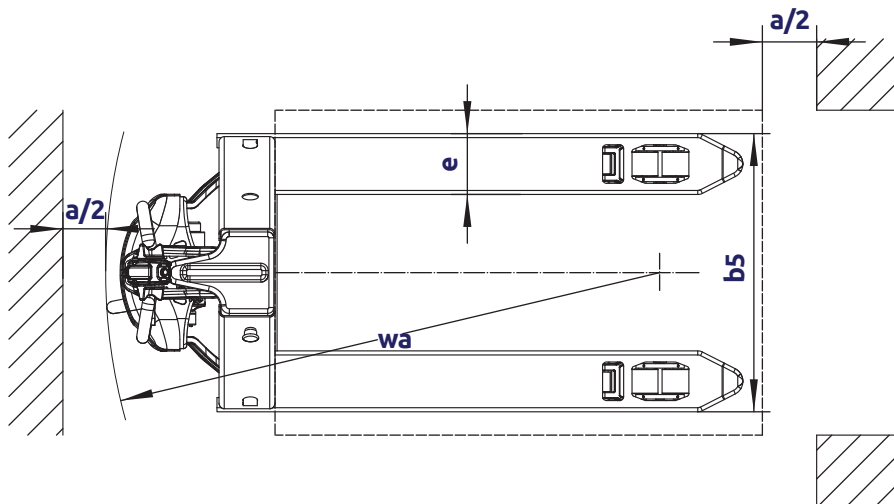
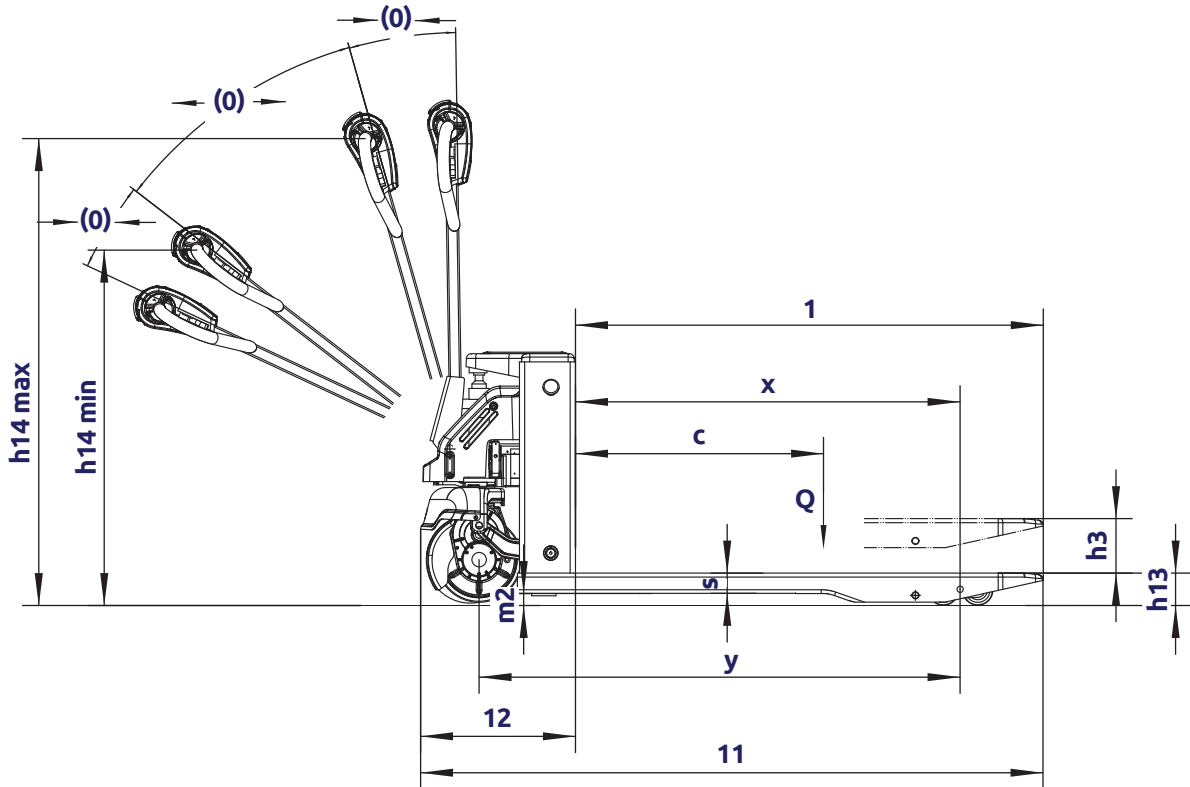

WARRIOR